

## Installation and Operating Instructions 0158

Lumiglas luminaire type USL 05-Ex/USL 05-LED-Ex

II 2G Ex d IIC T3/T4/T6/120°C

II 2D Ex tD A21 IP67 T195/T130/T80/T120°C

**Important, please note:**

Sight glass luminaires are specifically designed and solely intended for mounting with or onto flanged sight glass fittings. Under no circumstances should a sight glass luminaire be used on its own as a lid or cover for vessel openings or as a substitute for the cover flange or the complete sight/light port. Luminaires for use in potentially explosive environments must be mounted, installed and serviced by staff who have the relevant qualifications and have been properly trained for this type of work.

**Please observe the data set out in the EC type-examination certificate!**

**General operating conditions:**

- Independent of pressure/vacuum in the vessel
- Approved for use in Ex environments:  
Gas: Zones 1 and 2  
Dust: Zones 21 and 22
- **Approved for use in ambient temperatures between -20°C and +60°C or +40°C, depending on the lamp fitted (see type plate and temperature classification parameters).**

**Electrical data, general:**

- Voltage, power, temperature class and protection rating are shown on the type plate.
- Ex approval acc. to EC type-examination certificate:  
BVS 08 ATEX E 133
- II 2G Ex d IIC T3/T4/T6/120°C
- II 2D Ex tD A21 IP67 T195/T130/T80/T120°C
- The variant with integrated transformer is PTC-protected; no fuse replacement necessary
- Power supply: AC or DC voltage, depending on lamp fitted
- **Caution:** Only alternating current should be used for luminaires with a built-in transformer.
- **Warning:** Over-voltage will cause premature lamp failure!
- 10% voltage tolerance is admissible
- Please note: Flash frequency if used as a flash-lamp is  $\leq 1$  Hz

**Parameters/Temperature classification:**

| No. | Type USL 05-Ex<br>Type USL 05-LED-Ex<br>Variant | Part No.    | Voltage<br>Volt | Built-in<br>trans-<br>former | Halogen lamp<br>or LED illuminant |        | Ambient temperature range                               |           |   |           |
|-----|---|-------------|-----------------|------------------------------|-----------------------------------|--------|---|-----------|---|-----------|
|     |   |             |                 |                              | Voltage                           | Socket | $-20^{\circ}\text{C} \leq T_a \leq +40^{\circ}\text{C}$ |           | $-20^{\circ}\text{C} \leq T_a \leq +60^{\circ}\text{C}$ |           |
| 1   | (12 V) 5 W                                      | 3540.031.00 | 12 ≈            | without                      | 12 V/5 W                          | G4     | 2G T6   | 2D T80°C  | 2G T4   | 2D T130°C |
| 2   | (120 V/12 V) 5 W                                | 3540.032.00 | 120 ~           | with                         | 12 V/5 W                          | G4     | 2G T6   | 2D T80°C  | 2G T4   | 2D T130°C |
| 3   | (230 V/12 V) 5 W                                | 3540.033.00 | 230 ~           | with                         | 12 V/5 W                          | G4     | 2G T6   | 2D T80°C  | 2G T4   | 2D T130°C |
| 4   |   |             |                 |                              |                                   |        |   |           |   |           |
| 5   | (12 V) 20 W                                     | 3540.035.00 | 12 ≈            | without                      | 12 V/20 W                         | G4     | 2G T4   | 2D T130°C | 2G T3   | 2D T195°C |
| 6   | (24 V) 20 W                                     | 3540.037.00 | 24 ≈            | without                      | 24 V/20 W                         | G4     | 2G T4   | 2D T130°C | 2G T3   | 2D T195°C |
| 7   | (24 V) 20 W                                     | 3540.036.00 | 24 ≈            | without                      | 24 V/20 W                         | G4     | 2G 120°C  | 2D T120°C | -   | -         |
| 8   | (24 V) 20 W (f $\leq$ 1Hz)                      | 3540.038.00 | 24 ≈            | without                      | 24 V/20 W                         | G4     | 2G 120°C  | 2D T120°C | -   | -         |
| 9   | (230 V) 4 W-LED                                 | 3540.059.00 | 230 ≈           | without                      | 230 V/4 W-LED                     | GZ10   | -   | -         | 2G T6   | 2D T80°C  |

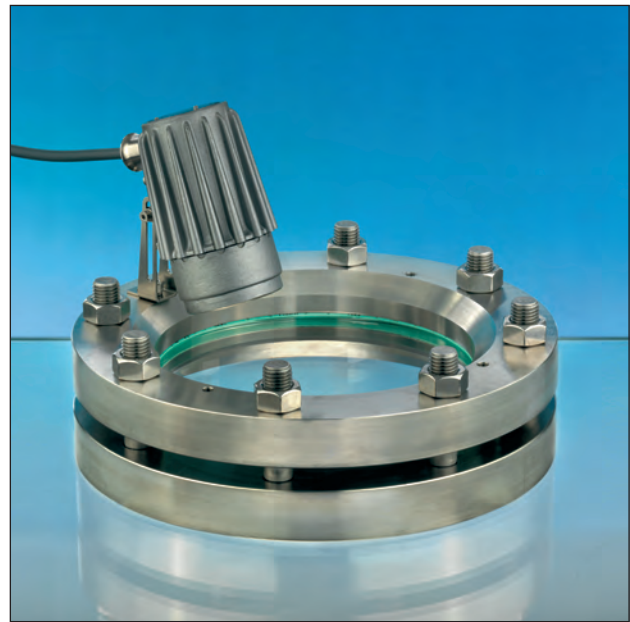

Application as combined sight and light port on a sight glass fitting acc. to DIN 28120, mounting by way of hinged bracket.

**Electrical connection:**

**Conditions/requirements:** This Ex-type luminaire has been manufactured with a permanently connected cable. The free ends of this lead must be installed in a category 2G/2D enclosure if connection is to be carried out in a potentially explosive environment. The luminaire and the area around the installation site should be cleared of dust prior to installation and in the course of maintenance work. The dismantled parts should be protected against dirt, dust and contamination during installation or servicing work. When closing the luminaire, special attention should be paid to ensure that the interior of the lamp is free of dust.

- The cable has already been connected inside the luminaire by the manufacturer and is ready for use.
- The external protective terminal (1) must be connected to a separate operational earth.
- The connecting cable should be secured after max. 1 m.
- Caution! If the cable is being replaced, e.g. by one of a different length, the inner terminals need to be loosened before unscrewing the cable gland.

**Replacing lamp:**

- Switch off power.
- Allow sufficient time to cool down, see type plate.
- Undo locking screw (2) which releases the safety tab (3) for the screw-type glass lens (4).
- Unscrew glass lens (4) using only the special claw spanner.
- The defective lamp is then pulled out (2-pin type) or removed with a press-and-twist movement (GZ10 bayonet type).
- Hold the new lamp bulb (original products only, please) using a protective cloth – taking care not to touch it with your bare fingers. Carefully insert the replacement lamp: push the 2-pin bulb into its socket, or push-and-twist bayonet type lamps. Make sure the lamp is securely in position!
- Before closing the luminaire, re-lubricate the thread of the screw lens (e. g. with AEMA-SOL 6 from A.E. Matthes).
- Refit the glass lens (4) by screwing it into place until it is tight again (pressure on O-ring).
- The glass lens (4) is locked into position once the safety locking tab (3) engages in one of the notches.
- Retighten the locking screw (2).

**Warning:**

When replacing lamp bulbs, make sure that the light beam is evenly distributed over the glass lens as prescribed by the design. On no account should a 'hot spot' be allowed to occur outside the luminaire (caused e. g. by the incorrect position or condition of the lamp).

**Mechanical installation:**

The luminaire is attached to the cover flange of a circular sight glass fitting or visual flow indicator using the hinged bracket. With the screw-type sight glass fitting, the luminaire is attached to the slotted cover nut; alternatively, it can be mounted using a hinged bracket or a flanged adapter collar.

**The Lumiglas luminaire Type USL 05-Ex is suitable for sight glasses in the following nominal sizes, using the appropriate mounting:**

| Type of fitting                                     | from DN | Hinged bracket | Flanged adapter collar |
|---|---------|----------------|------------------------|
| Circular sight glass fitting                        |         |                |                        |
| DIN 28120   | 25      | +              | -                      |
| DIN 28121   | 40      | +              | -                      |
| Visual flow indicator                               | 50      | +              | -                      |
| Screw-type sight glass fitting similar to DIN 11851 | 65      | +              | +                      |
|   | 80      | +              | +                      |
|   | 100     | +              | -                      |
|   | 125     | +              | -                      |

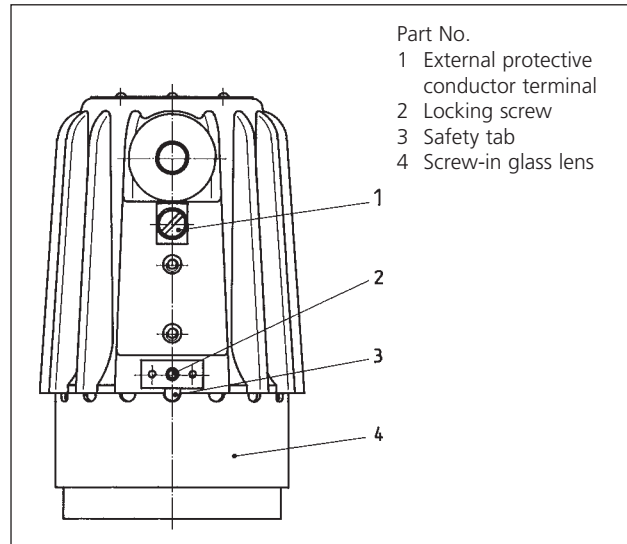

- Part No.
- 1 External protective conductor terminal
  - 2 Locking screw
  - 3 Safety tab
  - 4 Screw-in glass lens

**Mounting by way of hinged bracket:**

The hinged bracket is used to secure the luminaire to the cover flange of a circular sight glass fitting (also suitable for visual flow indicators). Alternatively, it can be attached to the slotted cover nut of screw-type sight glass fittings to DIN 11851. The hinged bracket is fixed in place by turning the supplied M6 bolt into a blind hole which has previously been tapped in the pitch circle of the cover flange face. An additional option is to weld on the bracket.

**Mounting by way of flanged adapter collar:**

The flanged adapter collar is bolted or welded to the slotted cover nut (DIN 11851).

**Please note:**

Fastening and mounting elements, claw spanner, etc. should be ordered separately if needed.

**Replacement parts:**

|  | Part No.    |
|--|-------------|
| Screw-type lens (light aperture) with reflector    | 1774.022.00 |
| Screw-type lens (light aperture) without reflector | 1774.030.00 |
| O-ring seal (Viton)                                | 0862.036.00 |

|                         |             |
|-------------------------|-------------|
| Lamp socket G 4 (2-pin) | 1202.011.00 |
| Lamp socket GZ 10       | 1202.024.00 |

|  |             |
|--|-------------|
| Cable entry gland complete with 2 m connecting cable | 1084.013.00 |
| complete with 5 m connecting cable                   | 1084.015.00 |
| complete with 20 m connecting cable                  | 1084.017.00 |

|                                      |             |
|--------------------------------------|-------------|
| (Halogen) lamps / LED illuminant:    |             |
| 24 V/20 W – G4                       | 3232.206.00 |
| 24 V/20 W – G4 (reflector spot lamp) | 3232.222.00 |
| 12 V/20 W – G4                       | 3232.229.00 |
| 12 V/5 W – G4                        | 3232.221.00 |
| 230 V/4 W – GZ10-LED                 | 3232.004.00 |

**Accessories:** Claw spanner

6816.001.00

**Service:**

- Keep luminaire clean.
- Keep note of average lamp life.
- Use only original replacement parts.

All dimensions in mm unless stated otherwise. Subject to change without prior notice.  
ric 05.10 0093.027.00 a